

COMPONENT SYSTEMS: ADVANCED FABRICATION

Visual Studies Spring 2009 / 2nd session
Professor: Joseph Vidich – jwv2102@columbia.edu

Week 04: Assignment 04

Final .dxf file of your Pavilion for SAP 2000 analysis
Create First full-scale detail model in chip or cardboard using the laser cutter
Begin thinking about assembly and fabrication processes.
Start modeling in Solidworks.

- **SAP 2000:** If you do not yet have a final .dxf line drawing for SAP analysis please finish this

- **LASER PROTOTYPE:** Using your Rhino model create a full-scale model of your detail connection system. This should be in chip or card board and done on the laser cutter. You may have to unfold parts of your model (if you have solid components) so that they can be cut flat and then folded back together. Remember to use a material that has the same thickness as your intended final material (for example if you are designing a detail using 1/8" steel then make sure you use 1/8" chip or cardboard on the laser cutter).

Please see attached images for the level of work I expect from this FIRST prototype and drawing set.

- **SOLIDWORKS MODEL:** we will begin to build your connection system in Solidworks on Monday, April 13th. You **MUST** have a detail designed in Rhino so that we can use this as a starting point for your Solidworks model.

- **SOLIDWORKS FEA:** We will begin to go over the Finite Element Analysis capabilities of Solidworks in class this Thursday. Once you have your model built we can input the data we received from SAP 2000 to get accurate stress and force diagrams on your specific connection systems.

- **FABRICATION LAB:** We will spend part of class this Thursday in the lab using some of the machinery so that I can demonstrate various metal milling and folding techniques. I will also bring some examples to class.

DUE: Thursday, April 16, 2009

1. **SAP 2000:** final .dxf file (lines only) of your pavilion: **Post .dxf file and an image of pavilion**
2. **RHINO:** Detailed sketch in of your connection system: **Post 2-3 images of your system.**
3. **SOLIDWORKS:** Begin building your connection system and bring your file so we can look at it in class.

Spatial Skin

COMPONENT SYSTEMS_Summer 2008
Assignment 03: Detail Prototype
Group 5_ Charles Valla, Jose Aragüez, Masaki Morinobu

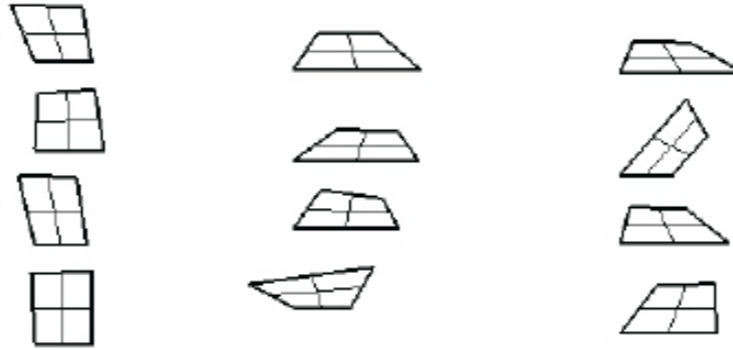

WOODEN PANELS

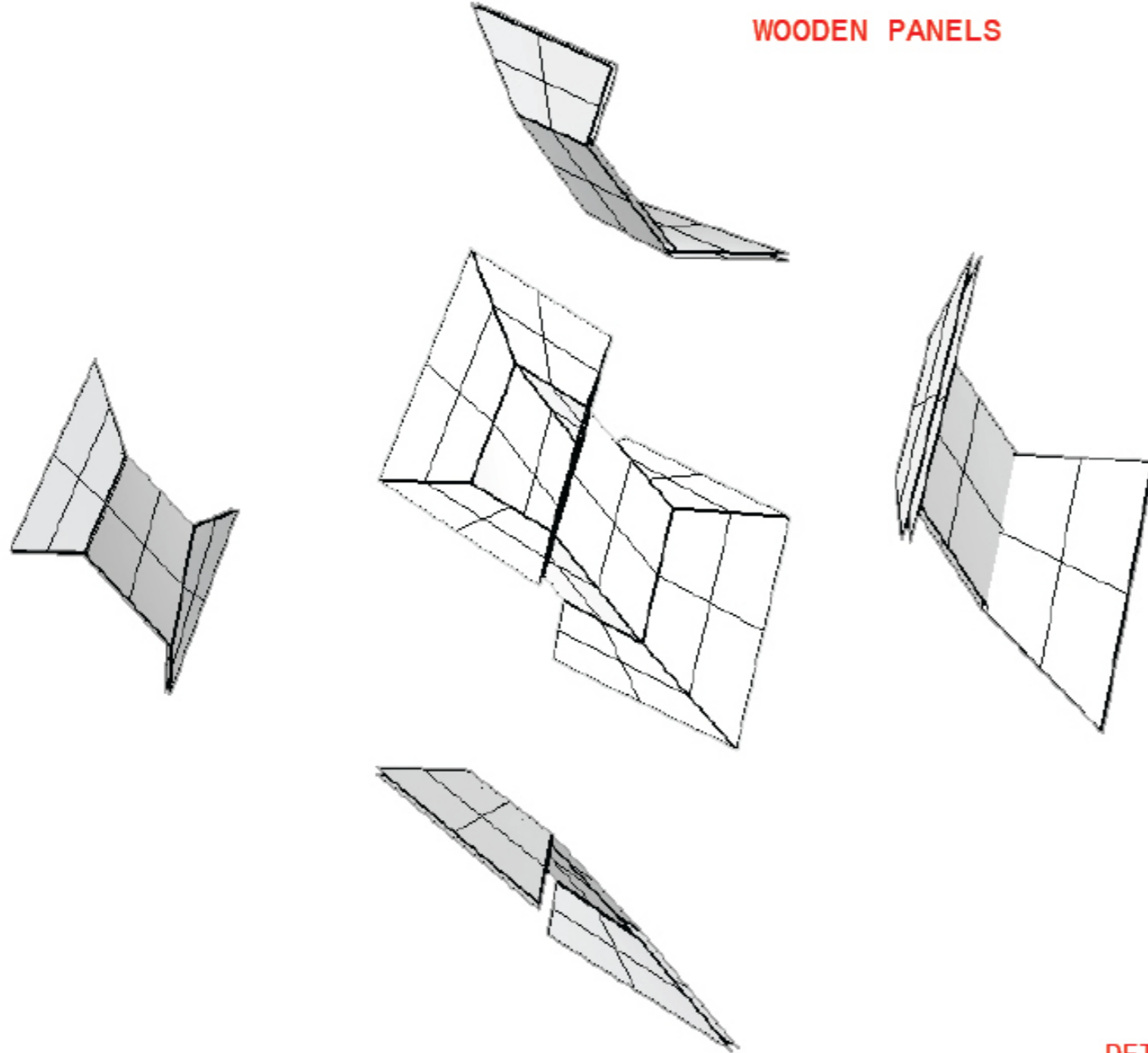

DETAIL. FIRST STEPS.



Spatial Skin

DETAIL EVOLUTION

COMPONENT SYSTEMS_Summer 2008
Assignment 03: Detail Prototype
Group 5_ Charles Valla, Jose Aragüez, Masaki Morinobu

